

RN5042 Batch 000000	Renault Grand Scenic Type Approval Number e11 00-8076
-------------------------------	---

COMPONENTS		
ITEM	QTY	DESCRIPTION
A	1	Towbar
B	1	Swan Neck (ZC1513)
B1	2	3mm Spacers
C	1	Side Arm (LH)
D	1	Side Arm (RH)
EP	1	Electrical Mounting Bracket (ZM1390)

BOLT PACK		
ITEM	QTY	DESCRIPTION
G	2	M12 x 70 Bolts & Nyloc Nuts
H	4	M12 x 40 Bolts, Washers & 2 Nuts
I	4	M10 x 45 Bolts & Washers
J	4	M10 H/D Washers – 30mm O/D x 5mm Thick

FITTING PROCEDURE

- ⇒ Remove rear light clusters (2 torx screws on inboard edge, 1 plastic nut & harness on rear of light, accessed through flap in internal boot panel). Remove bumper (2 plastic push-in plugs in each light cluster area, 6 torx screws on lower edge of bumper, 4 torx screws on top edge of bumper, 2 screws around perimeter of each wheelarch and an additional screw at each bumper tip (Hidden behind wheelarch liner). Pull bumper tips outward to release from clips along bumper to body edge. Disconnect plug for fog lights/reversing sensors on left hand side).
- ⇒ Remove and discard bumper impact beam (Hand to vehicle operator for retention). **Important:** Retain foil chassis seals, cut access holes as shown, and refit using original nuts, after first removing the metal tag in the chassis opening on LHS.
- ⇒ Lift boot floor covering, and if fitted boot mounted spare wheel. On 7 seat models fold rear seats forward and remove the rear storage box from the boot floor. Fold back edge of carpet to access the RHS mountings on the inside wall of the chassis - These are located behind a layer of foam padding. Remove rubber plugs from the mountings.
- ⇒ Access to the LHS mountings is achieved by removing the two rubber bungs on the outside of the rear wing and additionally the plastic vent (Partially hidden by the bumper frame). Remove rubber plugs from the mountings.
- ⇒ Insert side arms (C) & (D) through chassis seals, into chassis rails (Note the correct orientation) and loosely attach at the existing holes using bolts (I) with heavy duty washers (J) under the bolt heads.
- ⇒ Attach towbar (A) to side arms (C) & (D) using bolts (H). Fully tighten all bolts ensuring components are square and level.
- ⇒ **Important:** It is imperative that the chassis openings are sealed to prevent water ingress. (It is recommended that a suitable silicone sealant is used around the perimeter of the foil seals, side arm entry and mounting threads).
- ⇒ Refit vent and rubber bungs to rear wing. Reattach bumper and rear light clusters. Refit interior trim.
- ⇒ Attach swan neck (B) & electrical mounting bracket (EP) to towbar (A) using bolts (G) with 1 spacer (B1) at each side of the swan neck. **The electrical mounting bracket carries type approval information required by law and must always be fitted as shown.** Tighten bolts ensuring the towball remains vertical.

TIGHTEN ALL BOLTS

TORQUE SETTINGS ISO Coarse Pitch M8=29Nm, M10=58Nm, M12=102Nm, M16=252Nm
ISO Fine Pitch M8=31Nm, M10=61Nm, M12=111Nm

THE VEHICLE MANUFACTURER'S SPECIFICATION FOR THE TRAILER WEIGHT AND NOSE LOAD LIMITS MUST BE OBSERVED.

FITTING DIAGRAM

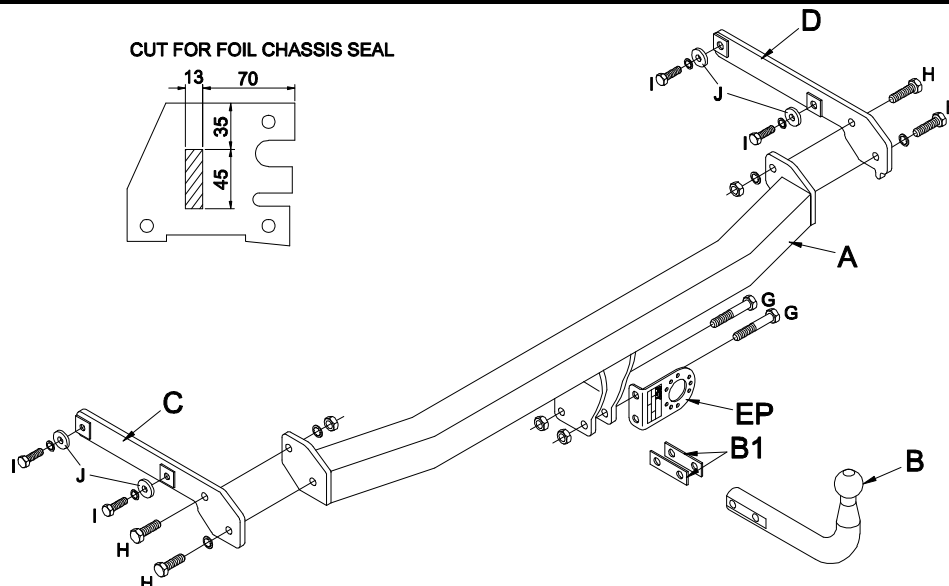

IMPORTANT PRODUCT INFORMATION & GUARANTEE

(TO BE RETAINED WITH THE VEHICLE AND PASSED TO SUBSEQUENT OWNERS)

Thank you for purchasing a PCT Automotive product. Please read the following information carefully before fitting or using your PCT Automotive product.

GUARANTEE

We shall free of charge either repair or at our option replace defective goods where the defects appear

- i. if the goods are a towbar manufactured by us, during the economic lifetime of the vehicle it was first fitted to
- ii. in the case of all other products manufactured by us, within 3 years following the date of your order

PROVIDED THAT (in each case) such defects shall be found to our reasonable satisfaction to have arisen substantially from our faulty design, workmanship or materials and have not arisen by reason of a failure to follow our instructions (whether written or oral), any modification, misuse, neglect or interference with the installation, any damage or abuse to the goods or vehicle by impact or vandalism or by a failure to carry out reasonable inspection, maintenance and/or adjustment.

At all times, the above guarantee is subject to our standard terms and conditions of sale a copy of which is available upon request from our offices.

TOWING LIMITS

Our towbars have been designed for towing up to the vehicle manufacturer's maximum recommended trailer weight and nose load limits for your model. Towing with gross weights above that recommended at any time will invalidate the guarantee and cancel any liability for damage. Towing a twin axle trailer, towing over rough ground or using a bicycle/motorcycle carrier, etc, exerts extreme loads on to a towbar and extra care should be taken in these situations not to exceed the vehicle manufacturer's maximum recommended limits.

PRODUCT IDENTIFICATION MARK

Your product carries a product identification mark. This mark carries important product and batch code information and if the product is type approved it also carries the type approval details which are required by law. Under no circumstances should this mark be defaced, removed or damaged.

INSTALLATION, INSPECTION, MAINTENANCE AND ADJUSTMENT

GENERAL INSTALLATION

- ⇒ Products should only be fitted by competent persons.
- ⇒ Read the product fitting instructions carefully and check all components are included in the fitting kit before commencing installation.
- ⇒ Check vehicle for corrosion and/or accident damage. Towbars should not be fitted to any vehicle suffering from corrosion or accident damage or which is not in a roadworthy condition.
- ⇒ Clean off all road dirt, underseal and sound deadening mastic where parts are to fit to ensure correct seating of all components.
- ⇒ Bumper cut information is given as a guide only. Variations in models may occur therefore the fitter should always check that the bumper cut is necessary and of the correct size and shape before commencing with the cut.
- ⇒ All drilling swarf should be removed from the vehicle and all holes drilled in the vehicle should be treated with an appropriate rust inhibitor.
- ⇒ Do not fully tighten bolts before towbar is completely fitted unless instructed to do so in the fitting instruction, this will allow some variances to be overcome before final tightening of bolts.

PAINT & CORROSION

Towbars manufactured by PCT Automotive undergo a phosphate chemical pre-treatment prior to an epoxy/polyester powder coat finish being applied. For long lasting good looks and in order to prevent corrosion the towbar should be regularly inspected for paint damage and wherever necessary re-painted in an appropriate finishing paint or underseal. The vehicle should also be regularly checked for any corrosion that could affect the towbar installation. Towbars should not be used on any vehicle suffering from corrosion that could affect the towbar installation.

BOLTS

All towbar fixing bolts should be checked initially after the first 300 towing miles and then every 3,000 towing miles or to coincide with the vehicle manufacturer's recommended service intervals, whichever is the sooner, and should be tightened using an appropriate torque wrench to the settings specified in the towbar fitting instruction.

ELECTRICAL INSTALLATION, TEST/COMMISSIONING AND MAINTENANCE

Failure to comply with the following instructions may cause damage to the towing vehicle's wiring loom and/or towing electrics installation.

Where displacement tap connectors e.g. Scotchlocks, are the preferred method of connection, always use the correct colour coded tap connector for the size of cable to which it is to be connected. PCT Automotive's manufactured relays with integral cables should be connected using red tap connectors (0.5mm² to 1mm², conductor cross sectional area).

After installation of the 12N/12S sockets, prior to testing, a water displacement agent e.g. WD40 should be applied into the rear connection void through the water drain hole at the bottom of the sockets and also into the front pins under the socket flap. This socket maintenance should be carried out at least twice a year in the spring and autumn.

The towing electrics test procedure must be undertaken with the engine running. If any of the towing relays fail to function correctly, with the engine running and no other vehicle electrical systems turned on, check that the voltage across the vehicle's battery is between 13V and 14V approx, if this voltage is not correct, check the condition of the vehicle's battery/alternator.

Always ensure that the trailer/caravan/lighting board's own electrical systems are installed and functioning correctly before coupling to the vehicle's 12N/12S sockets.

Every six months (spring and autumn recommended) the battery and alternator of the vehicle should be checked to determine correct electrical functioning. All connections of the electrical installation including the earth should be checked for mechanical soundness and electrical quality. Plugs, sockets, relays and fixings should be checked for water ingress, mechanical soundness, electrical quality and general wear and tear.

Please complete the following information to validate the guarantee and for future reference.

VEHICLE OWNER NAME & ADDRESS:

VEHICLE MAKE & MODEL:

VEHICLE REGISTRATION NUMBER:

FITTER NAME & ADDRESS:

DATE TOWBAR FITTED:

If you have any comments or suggestions about the PCT Automotive product fitted to your vehicle, please address them to PCT Automotive, Holbrook Industrial Estate, Sheffield S20 3GH or email techsupport@pctautomotive.com
Your comments will help us in our aim to continually upgrade our products to meet the high standards expected by our customers.